

A New Software Tool to Highlight Money Savings Made by a Demand Side Management System for Home Appliances

Sébastien Bissey, Sebastien Jacques, Jean-Charles Le Bunetel, Yves Raingeaud, Philippe Ravier, Guy Lamarque

► To cite this version:

Sébastien Bissey, Sebastien Jacques, Jean-Charles Le Bunetel, Yves Raingeaud, Philippe Ravier, et al.. A New Software Tool to Highlight Money Savings Made by a Demand Side Management System for Home Appliances. International Conference on Renewable Energies and Power Quality (ICREPQ'19), Apr 2019, Tenerife, Spain. hal-02103552

HAL Id: hal-02103552

<https://hal-univ-tours.archives-ouvertes.fr/hal-02103552>

Submitted on 18 Apr 2019

HAL is a multi-disciplinary open access archive for the deposit and dissemination of scientific research documents, whether they are published or not. The documents may come from teaching and research institutions in France or abroad, or from public or private research centers.

L'archive ouverte pluridisciplinaire **HAL**, est destinée au dépôt et à la diffusion de documents scientifiques de niveau recherche, publiés ou non, émanant des établissements d'enseignement et de recherche français ou étrangers, des laboratoires publics ou privés.

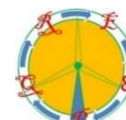

A New Software Tool to Highlight Money Savings Made by a Demand Side Management System for Home Appliances

Sébastien Bissey¹, Sébastien Jacques¹, Jean-Charles Le Bunetel¹,
Yves Raingeaud¹, Philippe Ravier² and Guy Lamarque²

University of Tours (France), GREMAN CNRS UMR 7347 INSA Centre Val-de-Loire
7 avenue Marcel Dassault, 37200 Tours (France)

Phone number: +33 2 47 36 13 24, e-mails: sebastien.bissey@univ-tours.fr, sebastien.jacques@univ-tours.fr,
lebunetel@univ-tours.fr, yves.raingeaud@univ-tours.fr

University of Orléans (France), PRISME UPRES 4229 INSA Centre Val-de-Loire
12 rue de Blois, 45100 Orléans (France)

Phone number: +33 2 38 49 48 63, e-mails: philippe.ravier@univ-orleans.fr, guy.lamarque@univ-orleans.fr

Abstract. In this article, a new software tool named “ECCO” is introduced. This one is intended to highlight money savings made by a home electricity management system. The simulation is based on a complete database of real electricity consumption patterns of AC loads. Two case studies are particularly described to point out the relevance of the simulation results. The first one consists in postponing the power demand using the delay start function of home appliances. The second one enables to smooth the electricity consumption from a storage system coupled with a converter. The management strategy described in this article uses the difference between electricity prices in peak time and off-peak time. The results demonstrate that this strategy is currently not profitable in France, but it is much more cost-effective in countries, such as in Australia, where this gap of pricing is higher.

Key-words

Smart grids, demand side management, individual housing, cost of electricity consumption.

1. Introduction

Nowadays, more than 80% of the primary energy consumption is still derived from fossil energies. In 2015, 86.8% of the primary consumption was based on non-renewable energy sources. According to the International Energy Agency (IEA), the global energy demand should increase by more than 30% by 2040 [1]. The Intergovernmental Panel on Climate Change (IPCC) has recently pointed out the need to reduce the global greenhouse gas emissions from 40% to 70% by 2050 (compared to the level recorded in 2010).

In 2015, the electricity demand accounted for 18.5% of the world's final energy consumption in comparison with 9.4% in 1973. Even if the share of carbon-free energies in the electricity mix has gradually increased in recent years, this constitutes only about 33.7% of the world's production. In spite of a continuous development of wind and solar energies, according to the World Energy Council, as a

mature technology, hydropower was the leading renewable source for electricity generation globally in 2016, supplying about 71% of all renewable electricity.

Integrating renewable energies into a traditional power system, which is designed to operate with a constant electricity input, is particularly challenging, among other things, because the energy supply must be reliable, and the energy costs must be controlled. In this context, a demand side management (DSM) system is especially useful in managing electricity consumption to warrant that the electrical grid and the end-use demands are fully balanced at all times. Thus, DSM represents a key component in energy management of smart grids and micro-grids.

Electricity cost optimization notably depends on the peak-demand reduction. Several alternatives to the traditional flat rate electricity pricing are currently proposed, such as real time pricing (RTP), critical peak pricing (CPP), time-of-use (TOU) or variable peak pricing (VPP) [2]. At the moment, the TOU pricing scheme, in which the electricity price varies throughout a day, is widely adopted by consumers in individual housing. In particular, a TOU scheme exhibits a higher electricity price during the peak period while maintaining a lower flat tariff for the rest of the day. Therefore, it is proposed to encourage consumers for primarily use electricity in off-peak time, and, *a fortiori*, to reduce their electricity bill.

An efficient DSM strategy must necessarily include price-based (or time-based) programs [3], [4]. In that case, a customer changes his/her electricity usage in response to changes in electricity prices. As can be seen in Figure 1, there are three possibilities to achieve this goal. The first one consists in shifting electricity consumption in off-peak time. In that case, an electricity management system which includes a storage system may be used. The second one consists in shifting the use of an appliance in off-peak time. The last one involves turning-off an appliance at a specific time.

This article describes a new software tool, named “ECCO”, developed in Python, intended to better predict and manage electricity demand in individual housing. This electricity prediction and management is based on real load curves characterized in several reference houses.

This manuscript is composed of three main sections. Section 2 describes the results of a complete experimental campaign. These data are of utmost importance to build the DSM program. Section 3 gives the architecture of the ECCO software tool. Section 4 discusses the results of two case studies. The aim is to point out the gain offered by a DSM strategy.

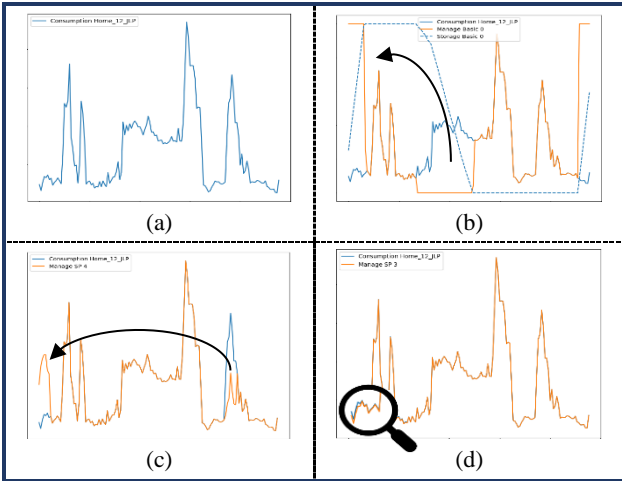

Fig. 1: Example of electricity management in individual housing: (a) Basic consumption; (b) Management using a home electricity management system composed of a storage system; (c) Management by shifting an appliance in off-peak time; (d) Management by turning off an appliance during the night.

2. Electric load shape characterization: a key element of the DSM strategy

Figure 2 shows an example of a smart home electricity management system (HEMS) which corresponds to a DSM system. This HEMS has been recently discussed in the literature [5]. It is intended to optimize the cost of

electricity consumption in individual housing. Specifically, it enables to smooth the electricity consumption, particularly by postponing it and/or erasing the peak demand. Thus, it helps the end-users to save money.

As can be seen in Figure 2, the proposed HEMS requires the implementation of a storage system (*e.g.*, batteries). The AC loads can be supplied in two ways *i.e.*, either from the AC grid, or an inverter in the situation where the storage system relieves the AC grid. These two operating modes can be managed by a bidirectional DC-AC converter. In that case, a smart system (*i.e.*, a user interface) is mandatory to control the converter. At the AC side, each AC load is coupled with a smart plug. This smart plug is a simple-to-use device which enables to switch any equipment on or off remotely at a specific time.

Such a smart HEMS necessarily involves costs, especially due to the use of a storage system. Even if the ECCO software tool is primarily dedicated to electricity demand prediction and management, it may be also used to help any end-user to design the best HEMS depending on the electricity consumption patterns, while at the same time minimizing the cost of the whole system.

One of the most important elements in the DSM strategy consists in using real patterns to accurately predict and manage electricity consumption. The ECCO software tool uses a complete database of real load curves. It means that each equipment inside a house can be characterized by a chart which represents its typical power demand as a function of time [6]. An experimental protocol was set up to get typical load curves. The technical specifications of the experimental measurement system are:

- It must be adaptable to most of appliances in the house.
- The electricity consumption of each AC load or a group of AC loads (*e.g.*, lights, heaters...) must be distinguished.
- The system must record the electricity consumption of many equipment with steps of one minute.
- The database of electricity consumption patterns must be exportable.

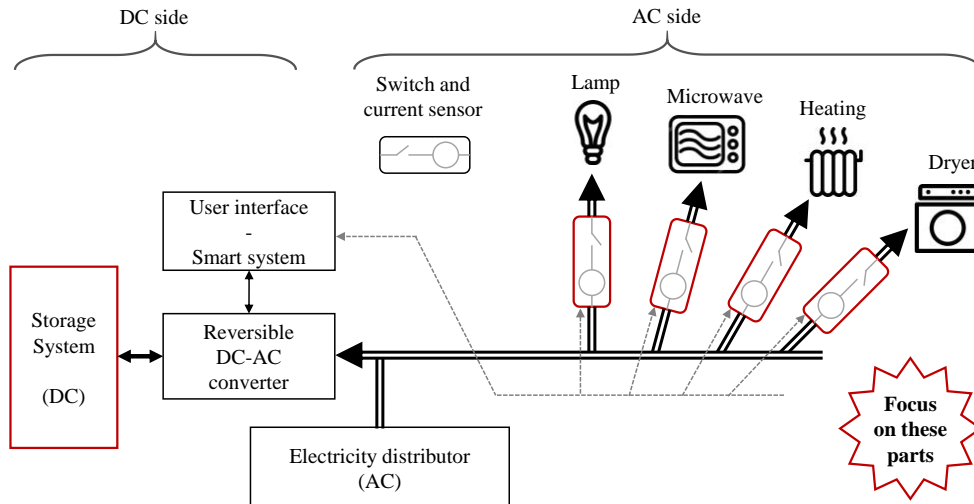

Fig. 2. Example of a smart HEMS which can be implemented in individual housing [5].

A. Experimental measurement of electricity consumption

All electricity consumption data described in this article were obtained with a programmable logic controller (PLC, reference: 6028-2483; manufacturer: WAGO). This kind of controller was mainly chosen because of its high modularity. It is important to note that the smart electricity meter could have been used. However, in that case, many complex algorithms should have been installed to differentiate each appliance in the house. The smart plugs could have been also used instead of the PLC. However, a smart plug is not capable of characterizing a high electricity consumer such as an oven. Moreover, the duration between two records (about a few minutes) is typically too long. Finally, data cannot be exported using a smart plug.

To carry out the experimental measurements, the PLC is composed of:

- Six power measuring 3-phase terminals.
- One terminal with four 24 V DC input digital channels.
- Two temperature sensors which enable to record indoor and outdoor temperatures.

Figure 3 shows how the connections were made to measure the electricity consumption of an instrumented house. Even if this solution is fully versatile, it does not have the capacity to differentiate each appliance. The PLC enables to differentiate the consumption of AC loads' categories (*i.e.*, lights, heaters, plugs, oven, etc.).

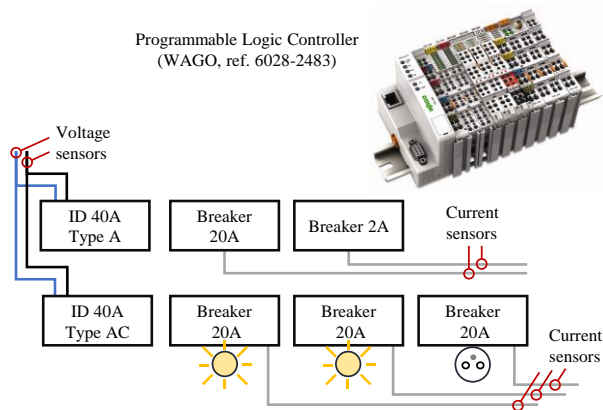

Fig. 3. Example of wiring of the measurement system in the electric panel of a smart home.

B. Electricity consumption monitoring in reference houses

A complete measurement campaign was carried out to instrument twelve reference houses. Table I gives the main features of the houses. It is important to note that the electricity consumption depends on the season. For example, 89% of the consumption of the first reference house is due to the heaters. As can be seen in Figure 4, the electricity consumption in the house n° 1 is strongly influenced by the external temperature. More accurately, the power demand depends on the difference between indoor and outdoor temperatures.

As can be seen in Table II, the electricity consumption monitoring is particularly useful to extract the standby consumption of each reference house. The results show that

many reference houses have a high standby consumption depending on the energy labels of the home appliances. For example, the fridge of the second house has an electricity consumption equal to 77.3 Wh. The standby consumption of the fourth reference house is mainly due to the continuous mandatory ventilation (its electricity consumption is about 64 Wh). Conversely, several reference houses exhibit low standby consumption. For example, this is the case for the house n° 10 which is equipped with a home automation system. This kind of system enables to control home appliances automatically or remotely (*e.g.*, indoor and outdoor lights, heaters, ventilation, air-conditioning...).

Table I. Main features of each reference house

House type n°	Surface area (m ²)	Small appliances consumption (Wh)	Consumption of energy-inefficient appliances (Wh)	Monthly invoice (euros)
1*	130	2,773	38,190	170
2*	50	1,701	2,708	16
3**	35	2,566	6,084	27
4*	100	3,783	5,483	39
5**	150	11,942	45,847	244
6**	135	5,434	1,384	31
7*	35	830	4,628	23
8*	140	12,053	14,548	119
9*	140	13,876	24,839	168
10**	135	2,417	2,258	21
11*	100	4,629	33,406	172
12***	150	14,120	13,235	124

*Electric heating; **Gas heating; ***Heat pump

Table II. Standby consumption analysis of each reference house

House type n°	Mean standby consumption (Wh)	Annual invoice (euros)
1	26.4	33.9
2	110.5	141.6
3	49.75	63.7
4	82.7	106
5	64.7	82.9
6	92.1	118.1
7	9.43	12.1
8	163.1	209.1
9	93.3	119.56
10	22.8	22.9
11	44.6	57.2
12	40.6	52.0

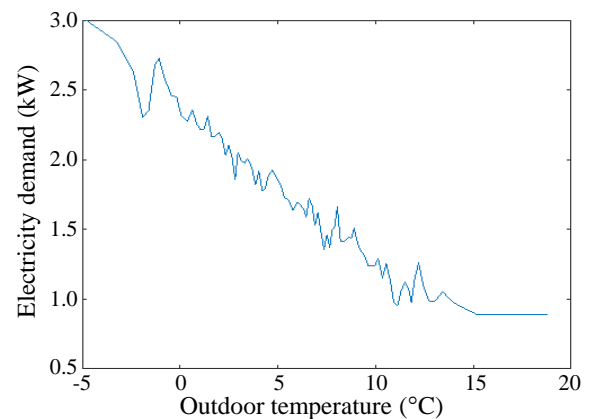

Fig. 4. Example of electricity consumption (reference house n° 1) depending on the outdoor temperature.

C. Examples of real electricity consumption patterns

The measurement campaign revealed three categories of loads' behaviors:

- Cycle and time-limited operations (e.g., heaters, washing machines, dishwashers...).
- Continuous cycle operation (i.e., on/off behavior).
- Without any typical cycle operation (e.g., computers, internet boxes...).

Regarding HEMS applications, the loads can be classified into three categories: shiftable, interruptible, and non-shiftable / uninterruptible. Cycle and time-limited operations can easily be shiftable in time, but they cannot be stopped. Continuous cycle operation and no cycle devices are shiftable and interruptible.

In this section of the article, two examples of real electricity consumption patterns are discussed. The first one, which represents the operation of a washing machine, is related to cycle and time-limited operations (see Figure 5). The second one, which deals with the electricity consumption of lights, is related to a continuous cycle operation (see Figure 6).

From Figure 5, the results show that the end-user started the washing machine at wrong times i.e., when electricity pricing was high. He should have used the delay start timer of the home appliance. This would not only have allowed the end-user to save money, but it would have enabled to avoid starting appliances at the same time and, *a fortiori*, creating a peak demand.

From Figure 6, the simulation results shows that lights cannot be shifted, but they must be turned on only when strictly needed.

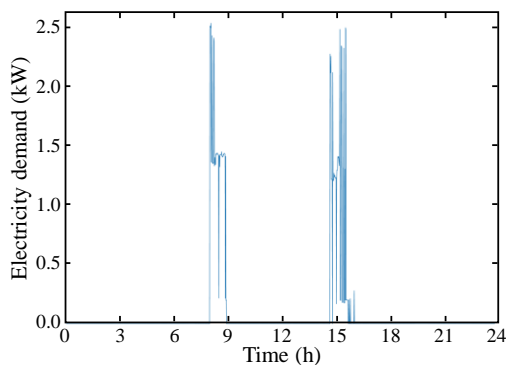

Fig. 5. Example of electricity consumption pattern of a washing machine.

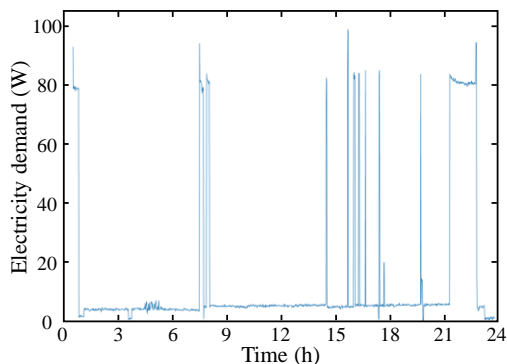

Fig. 6. Example of electricity consumption pattern of lights.

3. Architecture of the ECCO software tool

The proposed software tool, developed in the Python programming language, has been designed to group all measurement databases, an electricity prediction algorithm, and a HEMS into a single program.

As can be seen in Figure 7, the simplified flow chart of the program is composed of three categories of operation. Firstly, the “Software” operation is composed of non-visible elements, used by the software tool itself, to execute a code. Secondly, the “User choices” operation is the most important section of the proposed software tool, because it offers the end-user the possibility to proceed to a significant number of settings. Thirdly, the category named “Update interface” is used to sum up the main settings, give the main simulation results, and display the corresponding charts.

Regarding the choices of the end-user, the ECCO software tool proposes the following three sub-windows:

1. Databases: the end-user can select a type of house, the appliances, and the day of the simulation.
2. Prediction: the end-user can choose the prediction settings and run the prediction of electricity consumption of the selected house.
3. Management: the end-user can choose all settings to manage electricity.

There are three possibilities to manage electricity consumption: management using smart plugs, basic management using a storage system, and smart management using a storage system.

The management using smart plugs consists in simulating the electricity savings that can be made using smart plugs. A pattern recognition algorithm is implemented into the software tool, especially to manage energy-inefficient appliances such as washing machines, dryers etc. In that case, an example of management consists in postponing their operation during off-peak times and/or starting them at the same time. Specifically, the aim of the pattern recognition algorithm is to identify the number of start and stop of the appliances in the selected day, and then save all information.

The basic management of electricity consumption consists in simulating a scheme composed of a storage system and an AC-DC bidirectional converter. In that case, the aim is to save money by shifting the electricity consumption during off-peak hours.

The smart management of electricity consumption is proposed both to save money and avoid peak demand. To save money, the storage system can be used as soon as the price of the electricity is high. A part of the storage system is set aside and used only when the system detects a peak-load demand. The more the storage system is used, the greater money savings. However, an algorithm is necessary to optimize the operation of the storage system. In practice, the smart management system predicts the electricity consumption and keeps a part of the storage system in an intelligent way to manage the peak-load demand. If this period of time does not occur, then the system releases this stored energy for non-peak electricity consumption.

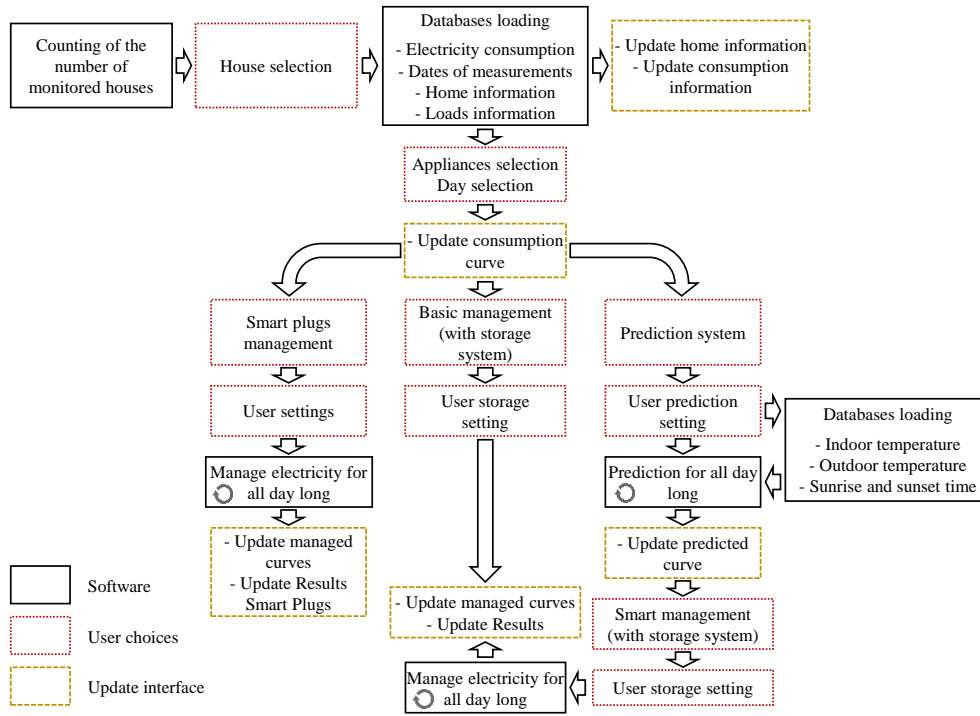

Fig. 7. Simplified flow chart of the ECCO software tool.

Regarding the simulation results, there are the following five sub-windows:

1. Home information: the electricity consumption can be sorted by appliances' category. For example this window points out the proportion of an energy-inefficient appliance (*e.g.*, heaters) in the total electricity demand of the selected house.
2. Consumption information: other information about electricity consumption (*e.g.*, average and standby consumptions) are given here.
3. Charts: the main results (*i.e.*, electricity consumption information, prediction and management of energy consumption) are summarized in charts.
4. Results: the following main results are summed up here: electricity savings, money savings, and accuracy of the prediction strategy.
5. Smart plugs' results: it shows the money saved through the use of smart plugs.

4. Results and Discussion

In this section of the article, two operation modes of the management system are discussed: the management using smart plugs, and the management with a storage system. Some simulation results are given to point out the relevance of such management strategies.

A. Management of the cost of electricity consumption using smart plugs

In the proposed software tool, nine smart plugs' actions are available:

1. Turn off lights between midnight and 6 a.m.
2. Turn off the Internet box.
3. Turn off the fridge 10 min before the off-peak time.

4. Turn off the freezer 10 min before the off-peak time.
5. Turn off the heaters 30 min before the off-peak time*.
6. Turn off the heaters 15 min per hour*.
7. Shift the use of the dishwasher to the off-peak period.
8. Shift the use of the dryer to the off-peak period.
9. Shift the use of the washing machine to the off-peak period.

* Both actions cannot be used at the same time.

Table III summarizes the yearly money savings for all experimented houses depending on the smart plugs' actions.

Table III. – Yearly money savings (in euros) depending on the smart plugs' actions

House n°	Action 1	Action 2	Action 3	Action 4	Action 5*	Action 6*	Action 7	Action 8	Action 9
1	0.35	-	-	-	20.1	465	2.71	-	21.0
2	3.08	-	0.59	-	-	-	1.12	-	0.15
3	0.57	-	-	-	-	-	-	-	33.2
4	0.82	-	-	-	-	-	-	-	2.87
5	1.37	-	-	5.16	10.7	258	5.33	-	-
6	15.2	-	-	-	-	-	2.92	-	-
7	2.99	-	-	-	1.46	17.1	0.51	-	-
8	3.89	-	-	-	-	-	4.86	0.01	0.66
9	4.67	-	-	-	-	-	0.38	1.86	3.72
10	0.02	-	-	-	-	-	2.37	-	-
11	0.33	0.19	0.74	-	15.0	218	-	0.23	14.8
12	5.32	2.87	-	0.28	-	-	-	3.39	9.82

The results exhibit that the action n° 6 (*i.e.*, turn off the heaters 15 min per hour) provides the most significant yearly money savings.

Figure 8 gives an example of management strategy of a washing machine. The aim is especially to shift its operation to the off-peak hours (*i.e.*, action n° 9). Using this kind of strategy, it is possible to save up to 33 euros per year.

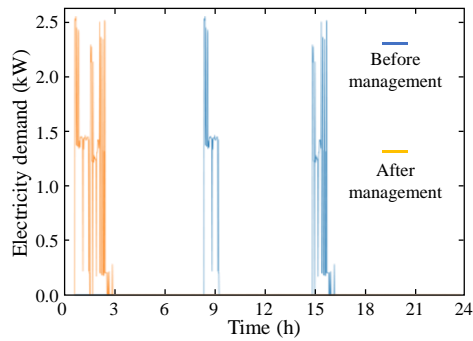

Fig. 8. Example of electricity consumption management of a washing machine using a smart plug.

B. Management of the cost of electricity consumption using a storage system

As can be seen in Figure 9, the storage system is used by the management system to postpone the electricity consumption in peak hours. The strategy is based on the choice of the storage capacity.

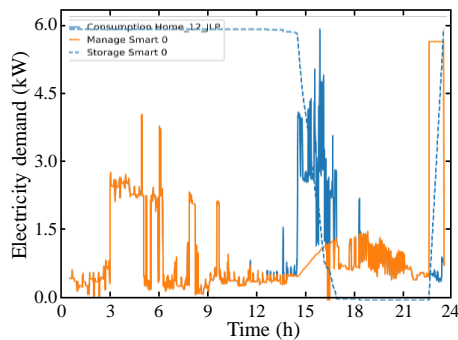

Fig. 9. Example of management with storage system.

The characterization results of the reference houses highlight that the mean daily electricity consumption of houses equipped with electric heating (*i.e.*, 17,858 Wh) during the peak hours is higher than the houses equipped with gas heating (*i.e.*, 4,792 Wh). Regarding the houses equipped with electric heating, the mean daily electricity consumption strongly depends on the season (*e.g.*, 10,228 Wh in the summer; 13,536 Wh in the autumn; 23,385 Wh in winter; 25,179 Wh in the spring).

Figure 10 shows a cost-benefit analysis of a management system equipped with a storage system coupled with a converter.

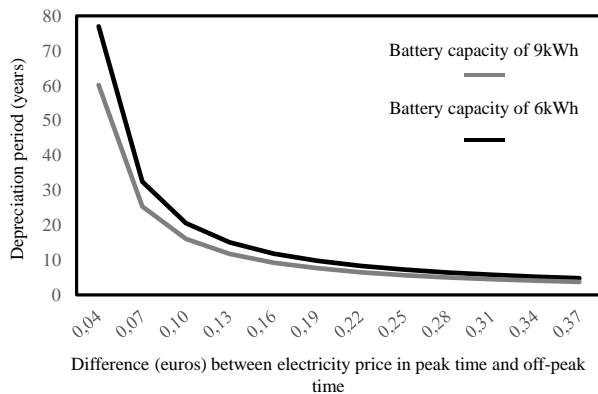

Fig. 10. Depreciation period of a management system (battery + inverter) according to the price of electricity.

The simulations were performed with the following assumptions: the prices of the storage system, the inverter, and the installation are about 200 euros/kWh, 800 euros, and 1,500 euros. From Figure 10, the more the price in peak time is high, the more cost savings.

5. Conclusions

In this article, a new software tool is proposed to get a better understanding of the cost of electricity consumption in individual housing. This software tool, named ECCO, is based on real consumption patterns of AC loads.

Two case studies are proposed to manage the cost of electricity consumption. The first one, which uses smart plugs, shows that electricity savings can be achieved by shifting the electricity consumption of energy-inefficient appliances (*e.g.*, washing machines...) to the off-peak hours. The second one, which is based on a storage system (*e.g.*, batteries) coupled with a converter, shows that it is possible to postpone the electricity consumption in peak hours.

The analysis of the depreciation period of a management system using batteries highlights that such a system is not profitable in France, because the difference between the electricity prices in peak time and off-peak time is low. However, this strategy may be interesting, for instance, in other countries where this gap is significantly higher. For example, such a system, implemented in a house located in Victoria (Australia), may have a depreciation period lower than ten years (the prices of electricity in peak hours and off-peak hours are about 0.33 euro/kWh and 0.08 euro/kWh respectively).

Acknowledgement

These research activities are currently supported by "Région Centre Val-de-Loire" (research project number: 2015-00099656). The authors of this manuscript thank our colleagues from this institution who provided insight and expertise that greatly assisted the project.

References

- [1] IEA, "World Energy Outlook 2017," 2017.
- [2] M. Verbič, S. Filipović, and M. Radovanović, "Electricity prices and energy intensity in Europe," *Util. Policy*, vol. 47, pp. 58–68, Aug. 2017.
- [3] M. Saffari, A. de Gracia, C. Fernández, M. Belusko, D. Boer, and L. F. Cabeza, "Optimized demand side management (DSM) of peak electricity demand by coupling low temperature thermal energy storage (TES) and solar PV," *Appl. Energy*, vol. 211, pp. 604–616, Feb. 2018.
- [4] A. Arcos-Vargas, D. Lugo, and F. Núñez, "Residential peak electricity management. A storage and control systems application taking advantages of smart meters," *Int. J. Electr. Power Energy Syst.*, vol. 102, pp. 110–121, Nov. 2018.
- [5] S. Bissey, S. Jacques, and J.-C. Le Bunetel, "The Fuzzy Logic Method to Efficiently Optimize Electricity Consumption in Individual Housing," *Energies*, vol. 10, no. 11, p. 1701, Oct. 2017.
- [6] A. Ridi, C. Gisler, and J. Hennebert, "A Survey on Intrusive Load Monitoring for Appliance Recognition," in *2014 22nd International Conference on Pattern Recognition*, 2014, pp. 3702–3707.